

U-BASE STANDS

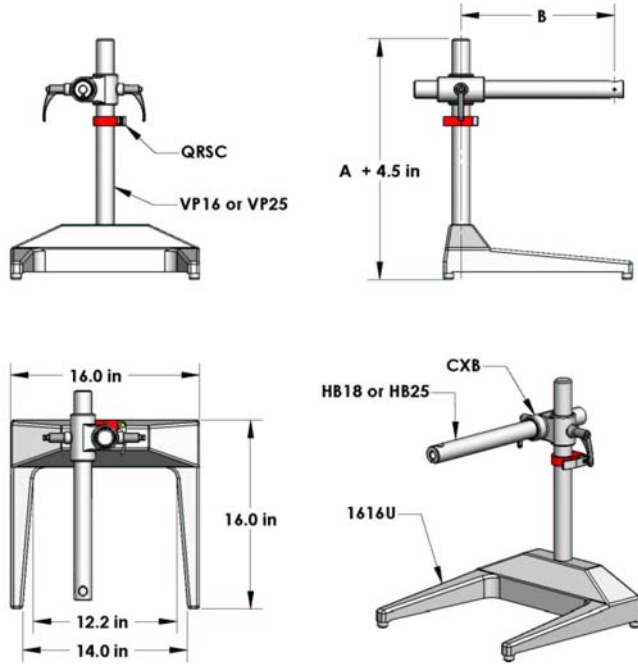
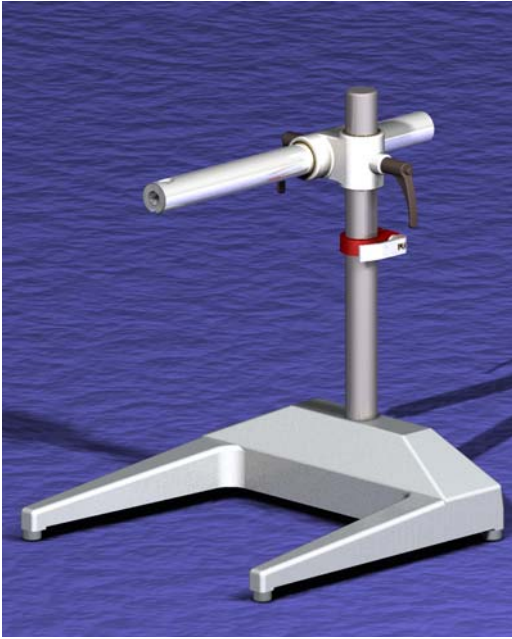

U-Base Stand Components

- 1616U 16" x 16" powder coated cast aluminum base with four rubber feet, 8 lbs.
- VP16 1 ½" diameter x 16" long stainless steel vertical post drilled to accept ½-13 UNC bolt.
- VP25 1 ½" diameter x 25" long stainless steel vertical post drilled to accept ½-13 UNC bolt.
- HB18 1 ½" diameter x 18" long keyed anodized aluminum horizontal bar with industry standard 5/8" "Bonder Pin" hole for end on, above or below mounting.
- HB25 1 ½" diameter x 25" long keyed anodized aluminum horizontal bar with industry standard 5/8" "Bonder Pin" hole for end on, above or below mounting.
- QRSC Red anodized aluminum safety clamp featuring a clear anodized aluminum quick release handle incorporating all stainless steel and brass hardware.
- CXB Cast aluminum, powder coated cross block with bronze bushings and adjustable handles.

Assembly Number	A* (in)	B (in)	C (in)	Stand Specific Components	Common Components
OS1616U-1618	16	14.75	¾	VP16, HB18	1616U CXB QRSC
OS1616U-2518	25	14.75	¾	VP25, HB18	
OS1616U-1625	16	21.75	¾	VP16, HB25	
OS1616U-2525	25	21.75	¾	VP25, HB25	

* Custom length vertical posts available upon request.



OLD SCHOOL INDUSTRIES, INC.

4678 Edie Place, Erie CO 80516

Phone: (303) 828-9093 FAX: (303) 828-9094

www.osi-incorp.com E-mail: info@osi-incorp.com