

STANDARD & HEAVY STANDS

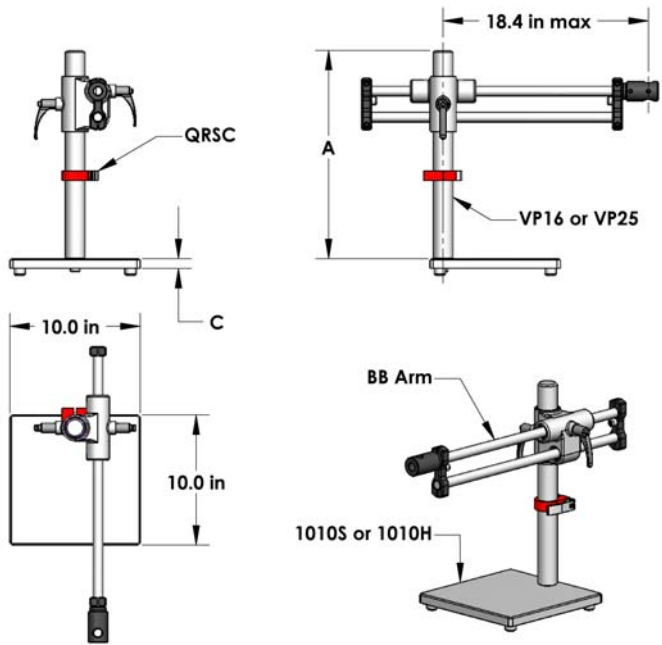
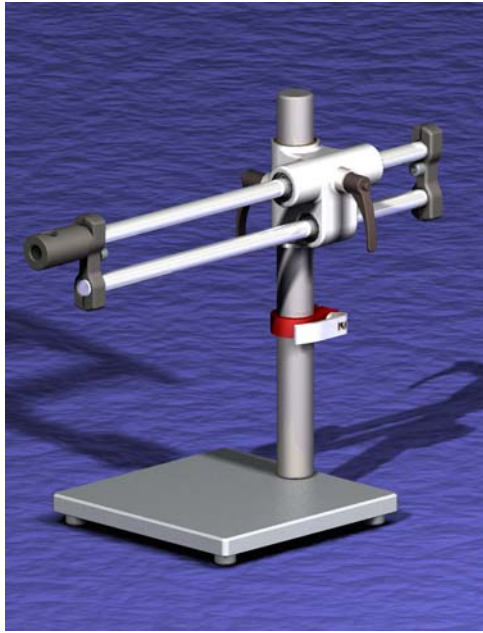

Ball Bearing Stand Components

- 1010S 10" x 10" x 3/4" powder coated steel base with four rubber feet, 21 lbs.
- 1010H 10" x 10" x 1 1/4" powder coated steel base with four rubber feet, 35 lbs.
- VP16 1 1/2" diameter x 16" long stainless steel vertical post drilled to accept 1/2-13 UNC bolt.
- VP25 1 1/2" diameter x 25" long stainless steel vertical post drilled to accept 1/2-13 UNC bolt.
- BB Cast aluminum, powder coated cross block featuring bronze bushings for the vertical axis and Thomson® linear ball bearings and dual hardened stainless steel shafting for the horizontal axis. Includes industry standard 5/8" "Bonder Pin" hole for end on, above or below mounting. Total horizontal motion 12 1/2".
- QRSC Red anodized aluminum safety clamp featuring a clear anodized aluminum quick release handle incorporating all stainless steel and brass hardware.

| Assembly Number | A* (in) | B (in) | Stand Specific Components | Common Components |
|--|---------|--------|---------------------------|---------------------|
| OS1010S-16BB | 16 | 3/4 | VP16 | 1010S BB QRSC |
| OS1010S-25BB | 25 | 3/4 | VP25 | |
| OS1010H-16BB | 16 | 1 1/4 | VP16 | 1010H BB QRSC |
| OS1010H-25BB | 25 | 1 1/4 | VP25 | |
| * Custom length vertical posts available upon request. | | | | |



OLD SCHOOL INDUSTRIES, INC.

4678 Edie Place, Erie CO 80516

Phone: (303) 828-9093 FAX: (303) 828-9094

www.osi-incorp.com E-mail: info@osi-incorp.com